

METAL FASTENERS CO., LTD.

CLINCHING NUTS 圓形壓鉚螺母 クリンチングナット

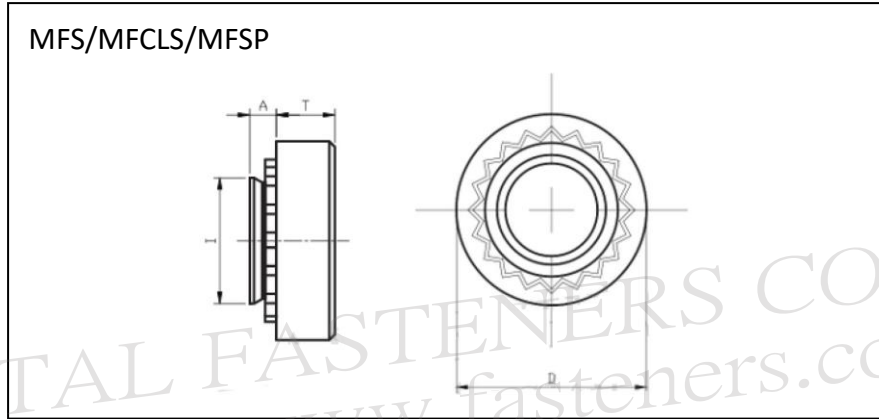

Material 材質 : Steel 鋼 スチール (MFS) / Stainless Steel 不鏽鋼 ステンレス鋼 (MFCLS)

Hardened StainlessSteel (400 series) 鈍化處理不鏽鋼 硬化ステンレス鋼 400系 (MFSP)

Finish 表面 : Cr3+ Zinc 三價鋅 三価亜鉛メッキ (MFS) / Plain 原色 脱脂 (MFCLS) /

Passivation Plain 鈍化原色 不動態化处理 (MFSP)

MFS / MFCLS / MFSP

Dimensions: ISO metric/mm

Part Code 產品編號 品番	Thread Size 螺紋尺寸 呼び径 x ピッチ	A (Shank) Max.	Min Sheet Thickness 最小板厚	Hole Size in Sheet 板孔徑 取付穴徑 +0.08	D ±0.25	I Max.	T ±0.25	Min. Dist. Hole C/L to Edge 最小板孔徑中心 至板邊距離 最小取付穴中心 と板端の距離
MFS/MFCLS-M2-0	M2x0.4	0.77	0.8	4.22	6.3	4.2	1.5	4.8
MFS/MFCLS-M2-1		0.97	1.0					
MFS/MFCLS-M2-2		1.38	1.4					
MFS/MFCLS-M2.5-0	M2.5x0.45	0.77	0.8	4.22	6.3	4.2	1.5	4.8
MFS/MFCLS-M2.5-1		0.97	1.0					
MFS/MFCLS-M2.5-2		1.38	1.4					
MFS/MFCLS-M3-0	M3x0.5	0.77	0.8	4.22	6.3	4.2	1.5	4.8
MFS/MFCLS-M3-1		0.97	1.0					
MFS/MFCLS-M3-2		1.38	1.4					
MFS/MFCLS-M4-0	M4x0.7	0.77	0.8	5.41	7.9	5.38	2.0	6.9
MFS/MFCLS-M4-1		0.97	1.0					
MFS/MFCLS-M4-2		1.38	1.4					
MFS/MFCLS-M5-0	M5x0.8	0.77	0.8	6.35	8.7	6.33	2.0	7.1
MFS/MFCLS-M5-1		0.97	1.0					
MFS/MFCLS-M5-2		1.38	1.4					
MFS/MFCLS-M6-0	M6x1.0	1.15	1.2	8.75	11.05	8.72	4.08	8.6
MFS/MFCLS-M6-1		1.38	1.4					
MFS/MFCLS-M6-2		2.21	2.3					
MFS/MFCLS-M8-1	M8x1.25	1.38	1.4	10.5	12.65	10.47	5.47	9.7
MFS/MFCLS-M8-2		2.21	2.3					
MFS/MFCLS-M10-1	M10x1.5	2.21	2.31	14	17.35	13.97	7.48	13.5
MFS/MFCLS-M10-2		3.05	3.18					
MFS/MFCLS-M12	M12x1.75	3.05	3.18	17	20.57	16.95	8.5	16.0

Part Code 產品編號 品番	Thread Size 螺紋尺寸 呼び径 x 山数	A (Shank) Max.	Min Sheet Thickness 最小板厚	Hole Size In Sheet 板孔徑 取付穴徑 +.003 -.000	D ±.010	I Max.	T ±.010	Min. Dist. Hole C/L to Edge 最小板孔徑中心 至板邊距離 最小取付穴中心 と板端の距離
MFS/MFCLS -256-0	.086-56 (#2-56)	.030	.030	.166	.250	.165	.070	.19
MFS/MFCLS -256-1		.038	.040					
MFS/MFCLS -256-2		.054	.056					
MFS/MFCLS/MFSP-440-0	.112-40 (#4-40)	.030	.030	.166	.250	.165	.070	.19
MFS/MFCLS/MFSP-440-1		.038	.040					
MFS/MFCLS/MFSP-440-2		.054	.056					
MFS/MFCLS-440-3		.087	.091					
MFS/MFCLS/MFSP-632-0	.138-32 (#6-32)	.030	.030	.1875	.280	.187	.070	.22
MFS/MFCLS/MFSP-632-1		.038	.040					
MFS/MFCLS/MFSP-632-2		.054	.056					
MFS/MFCLS-632-3		.087	.091					
MFS/MFCLS/MFSP-832-0	.164-32 (#8-32)	.030	.030	.213	.310	.212	.090	.27
MFS/MFCLS/MFSP-832-1		.038	.040					
MFS/MFCLS/MFSP-832-2		.054	.056					
MFS/MFCLS-832-3		.087	.091					
MFS/MFCLS/MFSP-024-0	.190-24 (#10-24)	.030	.030	.250	.340	.249	.090	.28
MFS/MFCLS/MFSP-024-1		.038	.040					
MFS/MFCLS/MFSP-024-2		.054	.056					
MFS/MFCLS-024-3		.087	.091					
MFS/MFCLS/MFSP-032-0	.190-32 (#10-32)	.030	.030	.250	.340	.249	.090	.28
MFS/MFCLS/MFSP-032-1		.038	.040					
MFS/MFCLS/MFSP-032-2		.054	.056					
MFS/MFCLS-032-3		.087	.091					
MFS/MFCLS-1224-1	.216-24 (#12-24)	.038	.040	.277	.370	.276	.130	.31
MFS/MFCLS-1224-2		.054	.056					
MFS/MFCLS-1224-3		.087	.091					
MFS/MFCLS/MFSP-0420-0	.250-20 (1/4-20)	.045	.047	.344	.440	.343	.170	.34
MFS/MFCLS/MFSP-0420-1		.054	.056					
MFS/MFCLS/MFSP-0420-2		.087	.091					
MFS/MFCLS-0420-3		.120	.125					
MFS/MFCLS-0518-1	.313-18 (5/16-18)	.054	.056	.413	.500	.412	.230	.38
MFS/MFCLS-0518-2		.087	.091					
MFS/MFCLS-0518-3		.120	.125					

PERFORMANCE DATE 性能數據表

MFS / MFCLS / MFSP

Dimensions: ISO metric/mm

TYPE 產品種類 型式コード	Thread Size 螺紋尺寸 呼び径	Sheet Material 板材料 相手母材	Installation (KN) 安裝力/圧入加力	Push-out (N) 推力/耐押抜力	Torque-out (N*m) 扭力/トルク
MFS MFCLS	M2	5052-H34 Aluminum 鋁板 アルミニウム	6.7 ~ 8.9	280	0.9
	M2.5			400	1.13
	M3			750	1.47
	M4		11.2 ~ 13.4	300	2.37
				470	2.6
				970	4
	M5		11.2 ~ 15.6	300	3
				480	3.6
				845	5.7
	M6		18 ~ 32	970	7.9
				1580	10.2
				1580	14.1
	M8		18 ~ 32	1570	13.6
					18.1
M10	22 ~ 36	1760	32.7		
M12	23 ~ 30	1390	35.2		

Part Code 產品編號 品番	Thread Size 螺紋尺寸 呼び径	Sheet Material 板材料 相手母材	Installation (KN) 安裝力/圧入加力	Push-out (N) 推力/耐押抜力	Torque-out (N*m) 扭力/トルク
MFS MFCLS	M2	SPCC 冷軋鋼板 冷間圧延鋼板	11.2 ~ 15.6	470	1.47
	M2.5			550	1.7
	M3			1010	2.03
	M4		18 ~ 27	490	2.95
				645	4
				1250	5.1
	M5		18 ~ 38	530	3.6
				800	4.5
				1112	6.8
	M6		27 ~ 36	1380	13
					1760
	M8		27 ~ 36	1870	18.7
					20.3
	M10		32 ~ 50	2020	36.2
M12	33 ~ 49	3065	73.9		

MFS / MFCLS / MFSP

Dimensions: ISO metric/mm

Part Code 產品編號 品番	Thread Size 螺紋尺寸 呼び径	Sheet Material 板材料 相手母材	Installation (KN) 安裝力/圧入加力	Push-out (N) 推力/耐押抜力	Torque-out (N*m) 扭力/トルク
MFSP	M3	304 Stainless Steel 不鏽鋼板 ステンレス鋼	35.6	575	1.58
			40	725	1.92
			44.5	1290	2.03
	M4		40	645	3.38
			44.5	800	4.18
			49	1600	5.08
	M5		42.3	800	3.95
			46.7	1025	5.08
			51.2	1775	6.77
	M6		60	2000	17
	M8		66	2100	19
	M10		80	2150	38

MFS / MFCLS / MFSP

Dimensions: inch

TYPE 產品種類 型式コード	Thread Size 螺紋尺寸 呼び径	Sheet Material 板材料 相手母材	Installation (lbs) 安裝力/圧入加力	Push-out (lbs) 推力/耐押抜力	Torque-out (in*bs) 扭力/トルク
MFS MFCLS	256 348 440	5052-H34 Aluminum 鋁板 アルミニウム	1500~2000	63	8
				170	13
				170	13
	632		2500~3000	63	16
				95	17
				190	22
	832		2500~3000	190	22
				68	21
				105	23
	024 032		2500~3500	220	35
				68	26
				110	32
	1224		2500~6500	190	50
				225	50
				120	63
	0420		4000~7000	285	70
				285	70
				220	70
	0518		4000~7000	360	90
				360	125
				360	125
				380	120
				380	160
				380	160

TYPE 產品種類 型式コード	Thread Size 螺紋尺寸 呼び径	Sheet Material 板材料 相手母材	Installation (lbs) 安裝力/圧入加力	Push-out (lbs) 推力/耐押抜力	Torque-out (in*bs) 扭力/トルク
MFS MFCLS	256 440	SPCC 冷軋鋼板 冷間圧延鋼板	2500~3500	105	13
				230	18
				230	18
	632		3000~6000	110	16
				130	20
				275	28
				275	28
	832		4000~6000	110	26
				145	35
				285	45
	032		4000~9000	285	45
				120	32
				180	40
				250	60
	1224		5000~6500	320	60
				200	74
				350	80
	0420		6000~8000	350	80
				315	115
	0518		6000~8000	400	150
420		165			
420		180			
				180	180

TYPE 產品種類 型式コード	Thread Size 螺紋尺寸 呼び径	Sheet Material 板材料 相手母材	Installation (lbs) 安裝力/圧入加力	Push-out (lbs) 推力/耐押抜力	Torque-out (in*bs) 扭力/トルク
MFSP	440	304 Stainless Steel 不鏽鋼板 ステンレス鋼(300系)	8000	130	14
			9000	165	17
			10000	290	18
	632		8500	140	18
			9500	170	24
			10500	340	28
	832		9000	145	30
			10000	180	37
			11000	360	45
			9500	180	35
	032		10500	230	45
			11500	400	60
	0420		13500	450	150