

METAL FASTENERS CO., LTD.

BROACHING NUTS 用於 PCB 之圓形螺母

基盤用ブローチングナット

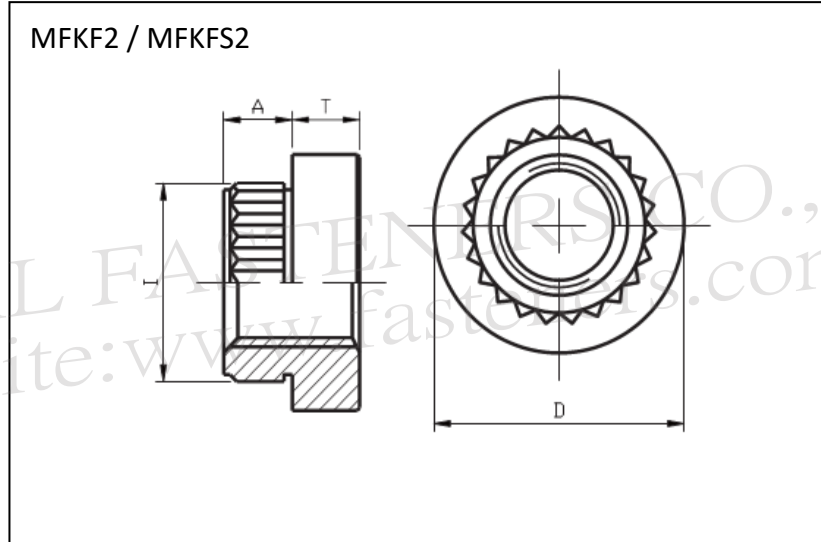

Material 材質：Steel 鋼 スチール (MFKF2) / Stainless Steel 不銹鋼 ステンレス鋼 (MFKFS2)

Finish 表面：Bright Tin 亮錫 光沢錫メッキ (MFKF2) / Plain 原色 脱脂 (MFKFS2)

MFKF2 / MFKFS2

Dimensions: ISO metric /mm

Part Code 產品編號 品番	Thread Size 螺紋尺寸 呼び径 x ピッチ	A Max.	Min Sheet Thickness 最小板厚	Hole Size In Sheet 板孔徑 取付穴徑 +0.08 (1)	D ±0.13	I ±0.08	T ±0.13	Min. Dist. Hole C/L to Edge 最小板孔徑中心 至板邊距離 最小取付穴中心 と板端の距離
MFKF2-M2 MFKFS2-M2	M2x0.4	1.53	1.53	3.73	5.56	4.19	1.5	4.2
MFKF2-M25 MFKFS2-M25	M2.5x0.45			4.22				
MFKF2-M3 MFKFS2-M3	M3x0.5			6.4	8.74	6.86	2	6.4
MFKF2-M4 MFKFS2-M4	M4x0.7			6.9	9.53	7.37	3	7.1
MFKF2-M5 MFKFS2-M5	M5x0.8							