

# METAL FASTENERS CO., LTD.

## THIN SHEET NUTS-INSERTS 金屬拉帽 リベットナット

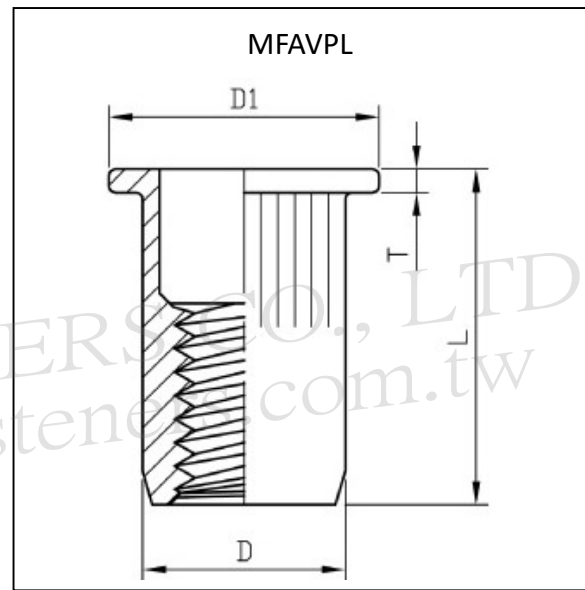
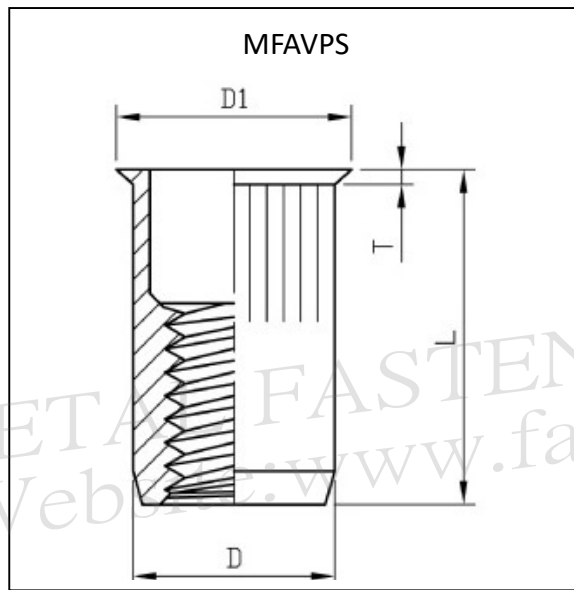

Material 材質 : Steel 鋼 スチール / Finish 表面 : Cr3+ Zinc 三價鋅 三価亜鉛メッキ

### MFAVPS

Dimensions : ISO meter/mm

Part Code 產品編號 品番	Thread Size 螺紋尺寸 呼び径 x ピッチ	D -0.15	L ±0.3	D1 ±0.25	T ±0.2	GRIP Range 鉚接厚度 グリップレンジ	Hole 組裝孔徑 取付穴径 +0.1
MFAVPS-M3	M3x0.5	5	9.00	5.7	0.40	0.5~1.5	5.0
MFAVPS-M4	M4x0.7	6	9.95	7.0	0.45	0.5~2.0	6.0
MFAVPS-M5	M5x0.8	7	12.00	8.0	0.50	0.5~2.5	7.0
MFAVPS-M6	M6x1.0	9	15.00	10.0	0.50	0.7~3.0	9.0
MFAVPS-M8	M8x1.25	11	16.00	12.0	0.50	1.0~3.0	11.0
MFAVPS-M10	M10x1.50	13	20.50	14.1	0.60	1.0~4.0	13.0
MFAVPS-M12	M12x1.75	16	24.00	17.15	0.60	1.0~4.0	16.0

### MFAVPL

Dimensions : ISO meter/mm

Part Code 產品編號 品番	Thread Size 螺紋尺寸 呼び径 x ピッチ	D -0.15	L ±0.3	D1 ±0.3	T ±0.2	GRIP Range 鉚接厚度 グリップレンジ	Hole 組裝孔徑 取付穴径 +0.1
MFAVPL-M3	M3x0.5	5.0	10.5	8.0	0.7	0.5~2.0	5
MFAVPL-M4	M4x0.7	6.0	11.0	9.0	0.8	0.5~2.5	6
MFAVPL-M5	M5x0.8	7.0	13.0	10.0	1.0	0.7~3.0	7
MFAVPL-M6	M6x1.0	9.0	16.5	13.0	1.5	0.8~3.0	9
MFAVPL-M8	M8x1.25	11.0	17.5	16.0	1.5	1.0~3.0	11
MFAVPL-M10	M10x1.50	13.0	21.0	17.0	2.0	1.0~3.5	13
MFAVPL-M12	M12x1.75	15.9	25.2	21.7	2.0	1.0~4.0	16